

Technical News Bulletin

Steinhausen, October 2002

Available for 81 / 503 / 515 / 555 Feeders

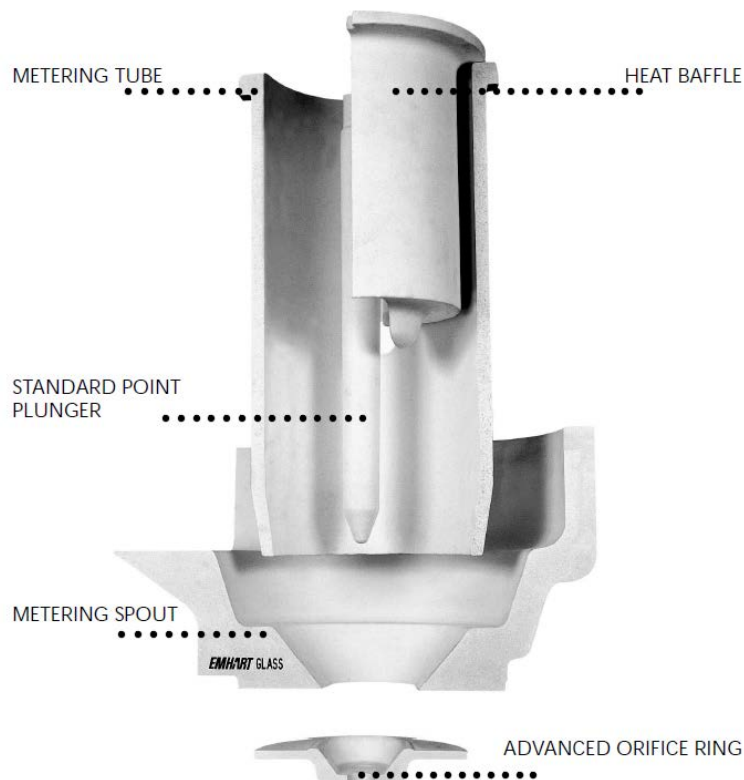

U.S. PATENT #5,665,138

Metering Spout Systems

- The Metering Spout System consists of an entire set of spout refractory components.
- Emhart Glass metering spout forms gobs of consistent weight, shape and temperature.
- The orifice ring, spout, tube and heat baffle constitute Emhart's Metering Spout System.

System Description

The Metering Spout System consists of an entire set of spout refractory components. The refractory components are specially designed to promote optimum gob forming conditions. The orifice ring, spout, tube and heat baffle constitute Emhart's Metering Spout System.

The metering spout and metering tube are the heart of the system. The sloped surface of the metering spout and tube create a metering valve. The tube is the valve stem of the metering valve and the spout acts as the valve seat. Moving the tube height up and down opens and closes the metering valve orifice with finite precision.

Refractory Components

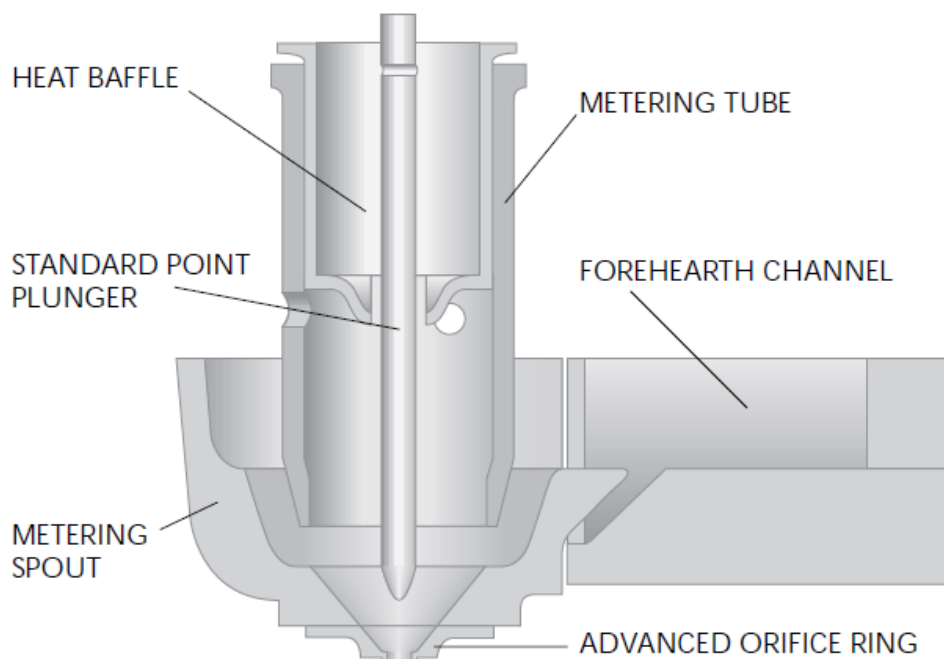

Besides regulating glass flow, the Emhart Glass metering spout forms gobs of consistent weight, shape and temperature. The spout throat and advanced orifice ring have an elliptical shape. This shape provides equal flow to each orifice. The heat baffle directs downward the spout fire coming through the tube vent holes. Deflecting the spout fire downward provides better gob temperature control.

Metering Spout Systems

Unique Features

Metering Spout and Tube regulate the Feeder's glass flow.

(U.S. PATENT #5,665,138)

The tapered shape at the bottom of the metering tube diverges from the tapered shape of the metering spout. The spout and tube together constitute a metering valve. The pressure of the glass flowing by the tube is distributed over the entire tapered surfaces of the tube and spout. Distributing the glass flow pressure decreases the wear to the tube and spout refractories. The diverging taper on the metering spout and tube reduces the spout's sensitivity to tube height changes. This drastically improves gob weight control.

Spout and Orifice Ring evenly distribute glass flow. (PATENT PENDING)

The spout throat and orifice ring allow for equalization of glass flow to all of the ring orifices. Computer modeling provided the optimal shape for the spout and orifice ring. The spout throat and orifice ring are basically elliptical, with a "dog bone" shaped cavity. This design creates space around the outside cavities to provide the needed flow patterns and eliminate the need for orifice ring cooling. The improved flow patterns in the spout bowl yield gobs of uniform weight, shape and temperature. This drastically reduces the characteristic "bowing" associated with double and triple gob production.



Computer modeling permitted Emhart to design the metering spout system

Velocity Profile Model

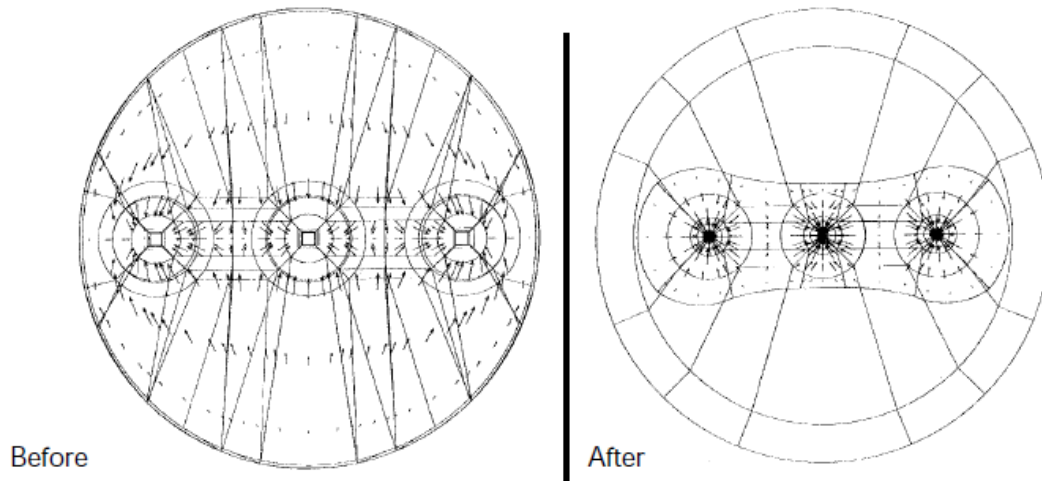

The Heat Baffle is a new refractory component.

(U.S. PATENT #5,593,472)

The heat baffle deflects downward the spout fires coming through the tube vent holes. The baffle also prevents heat loss from a potential chimney effect within the tube. This helps stabilize the gob temperature and protects the plunger chuck from heat.

Increased Spout Insulation

The new spout design has additional insulation in the lower portion of the spout. This is most evident around the critical throat area. The extra insulation enhances the thermal homogeneity of the glass temperature in the spout.



Metering Spout Systems Provide Visible Improvements

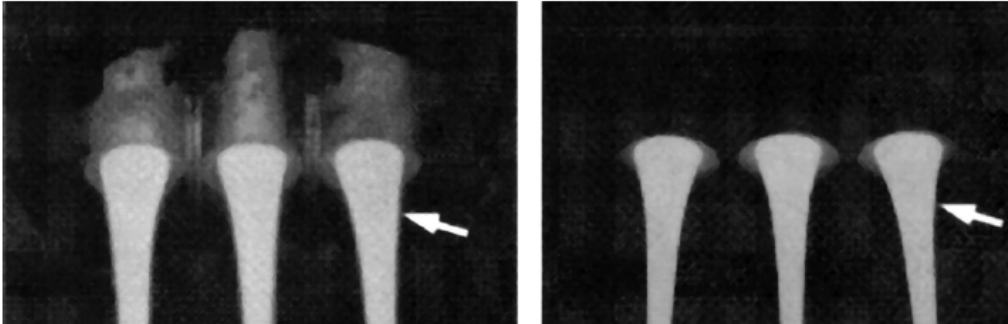

Benefits of Metering Spouts

- **Reduced gob weight variations**
Cut to cut
Orifice to orifice
- **Gob temperature is more uniform**
Cut to cut
Orifice to orifice
- **Gob loading improved**
Gob shape is constant
Gob bowing reduced
(double and triple gob)
- **Refractory wear reduced**
Orifice ring life improved
Tube life improved
- **Eliminates orifice ring cooling**

METERING SPOUT COMPARISON

GOB TEMPERATURE = 1150°

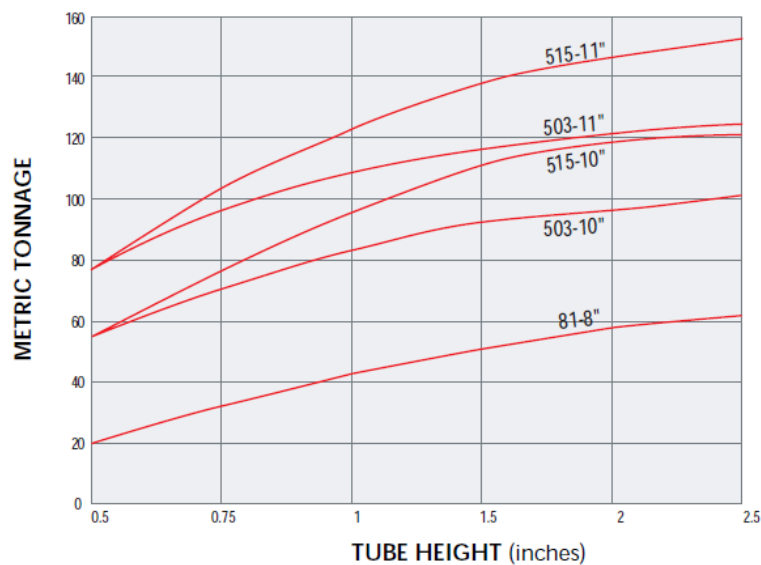

Installation Considerations

Spout Casing/Spout

The spout refractory installs into Emhart Glass' 81, 503, 515 and 555 spout casings. Retrofits and conversions are easily accomplished. The spout mating face is inclined and matches the slope on the spout transition channel. The "Spout and Channel Layouts" show the two pieces mating. Note that a different spout refractory is required for each shearing angle.

Spout and Channel Layouts

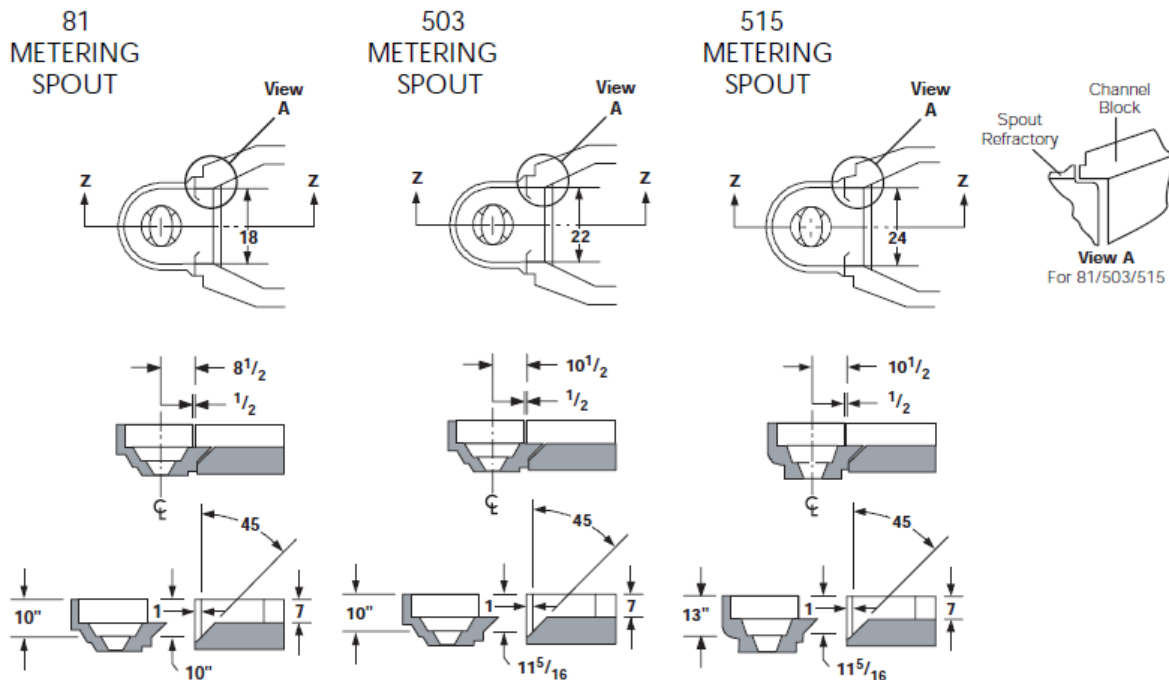

555 Tube Mechanism

The precision ground 8", 10" or 11" metering tubes are mounted with a self-centering mechanism (555-55). This mechanism is essential to make the metering spout system function as a precise metering valve. Conversions of existing 10" 555 tube mechanisms to 11" metering tube mechanisms are possible. The conversion kit number is 555-55-G15.

Delivery Center Distance

The current metering spout systems support the following:

8" Metering Spout	9" Metering Spout	10" Metering Spout	11" Metering Spout
S.G.	S.G.	S.G.	S.G.
D.G. 4 ³ / ₈ " C.D.	D.G. not available	D.G. 4 ³ / ₈ " C.D.	D.G. 4 ³ / ₈ " C.D.
	T.G. 3" C.D.	T.G. Not Available	T.G. 3" C.D.

Orifice Ring & Holder

The orifice ring for the metering spout has a special design that departs from the traditional orifice ring design. The design adds space around the outside cavities to promote the needed flow patterns. This space is not available with the normal orifice ring.

The newly designed orifice ring holder is recommended to install the new orifice ring. Alterations can be made to existing solid bridge orifice ring holders to convert them to the new design. The modifications to the orifice ring holder permit the slightly longer orifice ring to be positioned properly.

Configuration	503/515 Orifice Ring Holders	81 Orifice Ring Holder
SG	555-252-G02	
DG	555-252-G12	144-21839
TG	555-252-G11	

Plunger Refractory

The spout throat has been designed to work best with Emhart's standard point refractory plunger. The use of ball pointed plungers is not recommended. Select the plunger desired from drawing KS503-50.

Heat Baffle

The tube insulation cover supports the heat baffle refractory. The heat baffle assembly is semi-circular and requires two refractory pieces to accomplish its task. Assembly drawing 555-210 details the requirements for this assembly.



Drawings that help with the quoting/ specification process

Drawing #	Description	Drawing #	Description
555-209	Metering spout master list	<u>81</u>	
KS503-50	Plunger options	81-4699	Orifice ring D.G.
81-461	81 spout assemblies	555-210	Heat baffle assembly
503-245	503 spout assemblies	555-55	555 Tube mechanism
515-48	515 spout assemblies	81-461	Spout assembly (81)
555-99	555 spout assemblies	555-96	Spout cover assembly (503/515)
<u>503/515</u>		707-1007	Electrical installation of tube height & rotation controls
503-251	Orifice ring S.G.		
503-252	Orifice ring D.G.		
503-253	Orifice ring T.D.		