

# FleXinspect T<sup>180</sup>

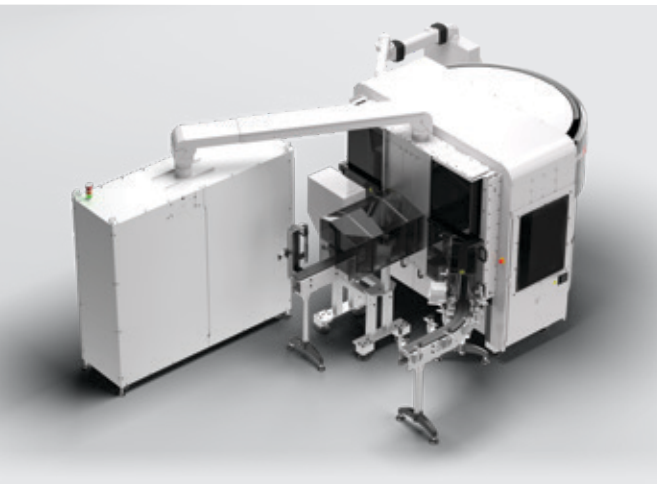

**A comprehensive inspection solution offering versatility, value and flexibility**

- Designed to be installed at the end of inspection loop conveyors as a “drop-in replacement” for older FP type machines.
- Reports inspection results and CID information directly into PIC systems currently supporting FP type machines.
- Runs faster than the existing FP style machines, reducing the number of machines to configure and maintain
- Operates on the “Generation III” technology, leading the way in artificial intelligence and deep learning solutions.
- Is a reliable and uniquely configurable platform that easily allows additional inspection functionality to be added.
- Provides unmatched modular versatility, value and flexibility for glassmakers’ current and future requirements.
- Can be configured as an “all in one” inspection machine performing all the required inspections for today’s glassmakers.



## Modernize your cold end without changing the layout

The FlexInspect T<sup>180</sup> allows glass plants to replace old machines with modern technology.

Replacing FP's with the FlexInspect T<sup>180</sup> lets glass plants utilize the space without additional expensive layout modifications. Its increased throughput reduces the number of inspection loops (2:1 reduction is typical) in factories.

### PIC compatible

- Reports the inspection results and CID information into the PIC system.
- A result can be configured to directly match the mapping from other FP machines installed on the line.

### Reduced line space and maintenance

- The "all in one" inspection configuration reduces the number of machines needed per inspection leg.
- High operational speed minimizes the number of inspection legs needed per forming line.
- Significant maintenance and labor savings are achieved due to fewer inspection machines in the production area.

### Complete cold end inspection

- Total inspection solution.
- Provides all the necessary cold end inspections.
- The unique design of the servo-driven handling devices allows inspections that are not possible with rotary inspection machines.

### Higher speeds and larger ware

- The 840mm starwheel design allows higher speeds on large diameter containers.
- The starwheel pocket configuration can be optimized to maximize container throughput.
- Synchronized servo motor motions optimize the machines, increasing efficiency.

### Precise container rotation

- A servo-driven rotator with a modular design improves operation.
- Servo technologies provide rotation performance feedback.
- Modular design allows maximum setup flexibility.

**Features**

- All inspections in one machine
- Modular/expandable inspection systems
- Cavity correlation of all defects
- Non-contact gauging for the finish
- Integrated inspection conveyors
- Brushless non-round container handling
- Traceability of change (who, what, when)
- 840mm servo-driven starwheel
- Five modular servo-driven rotation devices
- Servo-driven infeed screws
- Servo-driven starwheel
- Live belt outfeed handling system
- Auto challenge functionality (QC samples)

**Available Inspections**

- Modulated check detection
- Mold number reader - heel codes
- Vision plug/ring/dip/saddle/height
- Wall thickness - up to four elevations
- Two 'point out of round' (up to two positions)
- Mechanical plug/ring
- Mechanical dip/saddle/height
- Vision mold number reader - alpha numeric/bottom dots
- Sidewall opaque/sidewall transparent/sidewall stress
- Base/base stress
- Sealing surface/wire edge
- Dimensional (height, diameter, lean)
- Vision check
- ID read (matrix code reader)

**Ware Range**

- Height: 35mm-381mm
- Body Diameter: 16mm - 170mm

**Safety**

- Safety guarding, including entrapment tunnels
- Safe jog/run with two hand biometric control switches
- Safe torque off position monitoring and control

**Equipment Details**

| Pockets | Max. Diameter | Inspection Stations | Available Rotation Stations |
|---------|---------------|---------------------|-----------------------------|
| 9       | 170mm         | 5                   | 3                           |
| 12      | 152mm         | 7                   | 5                           |
| 18      | 107mm         | 10                  | 6                           |
| 24      | 79mm          | 13                  | 9                           |
| 30      | 66mm          | 16                  | 9                           |
| 36      | 53mm          | 19                  | 9                           |

**Typical Production Speeds**

| Type       | Pockets | Production Speed | Burst Speed |
|------------|---------|------------------|-------------|
| Large Ware | 9       | Up to 120        | 140         |
| Wine       | 12      | Up to 250        | 270         |
|            | 18      | Up to 300        | 320         |
| Beer       | 24      | Up to 350        | 370         |
|            | 30      | Up to 370        | 400         |
| Pharma     | 36      | Up to 350        | 370         |
| Non Round  | 9       | Up to 90         | 100         |
|            | 12      | Up to 165        | 180         |
|            | 24      | Up to 200        | 220         |

## Specifications

### Power requirements

380 to 480 VAC, 3 Phase, 25 Amps

NOTE: Transformer required for any other voltage.

### Air requirements

Minimum ..... 3.5 bar nominal [50 psi]

Maximum ..... 0.8 to 0.85 m3/minute

### Environmental considerations

Temperature Max. .... 50 °C [122 °F]

Relative humidity ..... Max. 95% relative humidity (non-condensing)

### Machine speed

Maximum of 400 bpm

Minimum of 60 bpm

(Speed is affected by container dimensions, shape, starwheel configuration, and plug penetration)

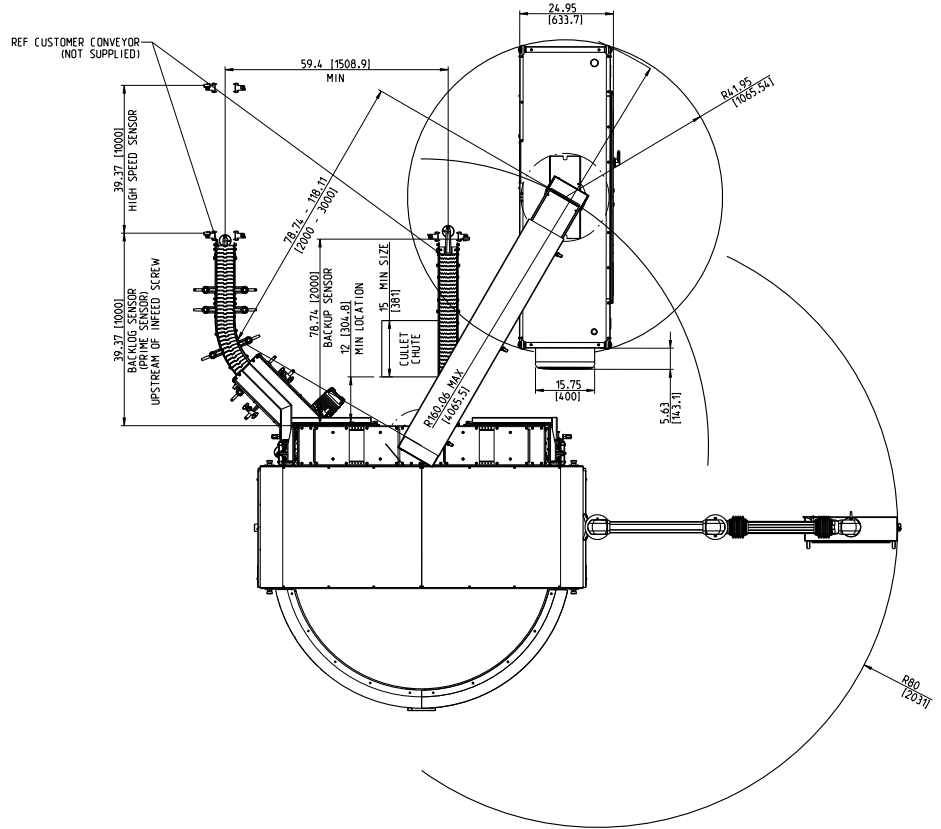

Specifications are subject to change. Actual performance depends on specific application, container size, and line speed. Dimensions represent nominal machine size and are not for installation purposes.

**Bucher Emhart Glass**  
 Hinterbergstrasse 22  
 CH-6312 Steinhausen  
 Tel. +41 41 749 42 00  
 Fax +41 41 749 42 71  
 webmaster@bucheremhartglass.com  
 www.bucheremhartglass.com

Bucher Emhart Glass is a company with a rich heritage and a tradition of excellence that we are proud to continue today. Our founders laid the foundations for automation in glass manufacturing, setting us on a course of market-leading innovations that has lasted for over a century. We created the industry-standard IS machine and have repeatedly delivered game-changing innovations in gob forming, container forming, automation, control and inspection.

Growing strategically through new branches, alliances and acquisitions, we have developed into a true global enterprise with the power to serve customers around the world with speed, responsiveness and understanding. Our global footprint provides the very best in established expertise, economical manufacturing, and hands-on client support.

Our work is underpinned by a profound and unshakeable belief in glass as a packaging material. And we back up that belief with investment in R&D. Driven by our clients' priorities, we continue to work towards new milestones in production speed, product quality, testing precision, and glass container strength. The ideas we have today will deliver the improvements of tomorrow.